

## Lapcom VX-2000 Lite-10 All User's Guide

### FOREWORD

Thank you very much for purchasing LAPCOM VX-2000 Lite-10 All and its related products.



Lite-10 All is a system that effectively supports engine and chassis setup for racing machines. It provides lap times, engine RPM, voltage, \*speed, and \*temperature. Most of this data can be monitored on a display by the driver, and memorized into the control unit up to 200 laps. \* Sensors are optional.

#### Lite-10 All Specification

Lap Memory	200Lap
Lap Timing	Magnetic or Infrared* * Infrared is optional.
Split Times	Up to 4 splits based on buried magnets
RPM	Digital display
Wheel Speed	Optional
Temperature	2ch. Optional * The measurement accuracy is dependable in the range of 5°C/41F to 300°C/572F.
Battery	Nickel Metal hydrate standard (Rechargeable)
Battery Life	13 Hours approximate.
Quick charging	Quick charging time 90 minutes with supplied charger. * Trickle charging of 14-15 hours is recommended for full charge.
Hour Meter	Engine running time hour meter. * This is available when the RPM is measured.
Odometer	Odometer. * This is available when the speed is measured.
Data Download	Download data to a computer for analysis. * An optional cable is required.
Shift lights	Programmable
Temp Alarms	Programmable
RPM Red line	Programmable
Sampling rate	10 Hz. (Ten samples per second)
Battery Alarm & Auto power off	When the battery is running low, a "V" starts flashing on the display and the power lamp will go out in about an hour due to the auto power off function.

### For your safety, observe the following

#### Warning Icons

	<b>Warning</b>	Ignoring this may result in death or serious injury.
	<b>Caution</b>	Ignoring this may result in injury or physical damage.
	<b>Alert</b>	Ignoring this may result in the disruption or suspension of function.



#### Attention

1. Copying all or part of this manual without permission is strictly prohibited.
2. The contents of this manual may not be modified without prior notice.
3. If you discover any errors, omissions, or any part that is unclear, we would appreciate your advising us.
4. Percul Co. accepts no liability or responsibility for any outcomes resulting from user operation, equipment failure, incorrect operation, or external factors.
5. The warranty is voided if any of these products is disassembled or modified without permission.





## CONTENTS

<b>SAFETY INSTRUCTION for USE</b> Please read.	3
1) Standard System Components	4
2) Parts and Connectors	4
3) Charging the Control Unit	5
4) Installation	6
1. Control unit	6
2. Magnetic sensor	6
3. Pulse lead for RPM	7
4. Wheel speed sensor	8
5. Liquid sensor	8
6. Spark plug temperature sensor	9
5) Setting of Parameters	9
1. Parameter No.1: Number of Segments	9
2. Parameter No.2: Sensor Off Timer	9
3. Parameter No.3: REV Position	10
4. Parameter No.4: Shift Lamp	10
5. Parameter No.5: Red Line	10
6&7. Parameter No.6&7: Temperature Alarm	10
8. Parameter No.8: Speed Pulse Length	11
9. Parameter No.9: Unit of Speed	11
10. Parameter No.10: Baud Rate	11
11. Parameter No.11: Backlight (Optional)	11
6) Selecting Data Item that can be Displayed during Driving	12
7) Monitoring Data during Driving	12
8) Reviewing Data from the Display	12
9) How to Delete Individual Lap Data	13
10) How to Delete all the Lap Data in a Single Block	13
11) How to Display and Reset Engine Running Time and Odometer	13
12) Data Download	14

## INSTRUCTIONS for USE

 <b>Warning</b>	<ul style="list-style-type: none"><li>- Do not disassemble or modify this device. Doing so could cause a fire, an electric shock, or damage to the device.</li></ul> <hr/> <ul style="list-style-type: none"><li>- If anything unusual emanates from the device such as smoke or a strange smell, immediately remove the plug from the power outlet.</li><li>- Remove the plug from the power outlet before conducting maintenance on this device. Leaving it plugged in could cause an electric shock. Regularly wipe dust from the plug. Leaving it for any length of time could result in fire.</li><li>- During thunderstorms, stop using the device, remove all cables from the device and the plug from the power outlet.</li></ul> <hr/> <ul style="list-style-type: none"><li>- This device has splash-proof construction. If it gets soaked it could cause a fire or an electric shock.</li><li>- Do not touch the power outlet with wet hands, as this could cause an electric shock.</li><li>- Do not modify the AC adapter, and do not bend, twist, damage, or apply heat to any of the cables.</li><li>- Use only the indicated voltage. Doing otherwise could cause a fire or an electric shock. When using other electric appliances together from the same power outlet, ensure that the total electric current does not exceed the circuit limit.</li><li>- Do not switch on the power to this device in the presence of inflammable gas or fluids as this could cause a fire.</li><li>- Do not use this device where the use of such devices is prohibited.</li></ul>
 <b>Caution</b>	<ul style="list-style-type: none"><li>- Use only the AC adapter supplied.</li><li>- Correctly insert the plug into the power outlet. Any metal that comes into contact with the AC adapter plug could cause a fire or an electric shock.</li><li>- Pull the AC adapter plug from the power outlet by the body. Pulling it out by the cord could cause a fire, an electric shock, or damage to the adapter.</li><li>- Before using these devices, read this User's Guide.</li></ul>
 <b>Alert</b>	<ul style="list-style-type: none"><li>- During operation, any cables that come loose or any connections that become unstable through vibration could cause a malfunction of this device. Do not apply stress to any of the connector joints.</li><li>- Do not exceed the prescribed time limit when charging the internal battery.</li><li>- If the internal battery is completely discharged, it could cause extreme deterioration of the battery's performance and loss of all the stored data in the device.</li></ul>

## 1) Confirm Standard System Components

 <p><b>Front</b></p>	 <p><b>Back</b></p>		
<p>Control unit (Data logger) with display</p>		<p>Magnetic sensor for kart *1</p>	<p>Pulse lead for RPM</p>
		<p>- Lite-10 All User's guide</p>	
<p>AC adapter and plug</p>	<p>Mount panel and screws</p>		

\*1 Optional Lap markers, High gain Magnetic sensor suitable for car.  
 Optical sensor (Infrared)  
 Price will vary according to sensor chosen

## 2) Buttons and Sensor Connections

Confirm the names of parts & connectors of the control unit.

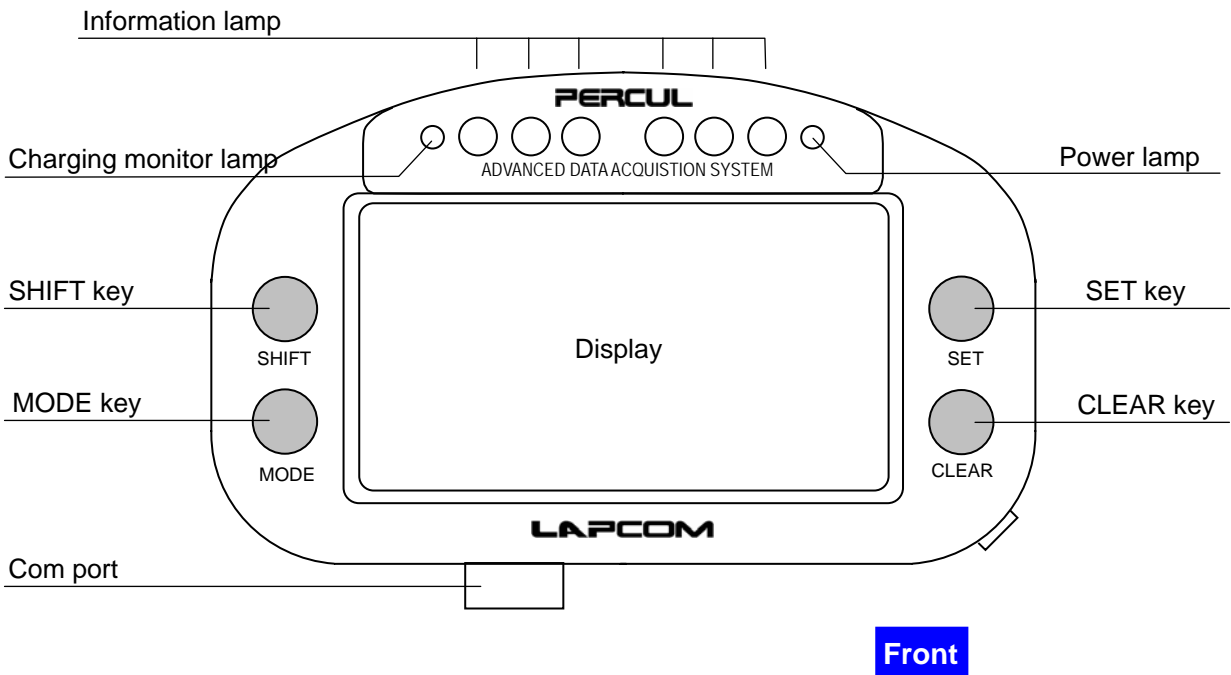

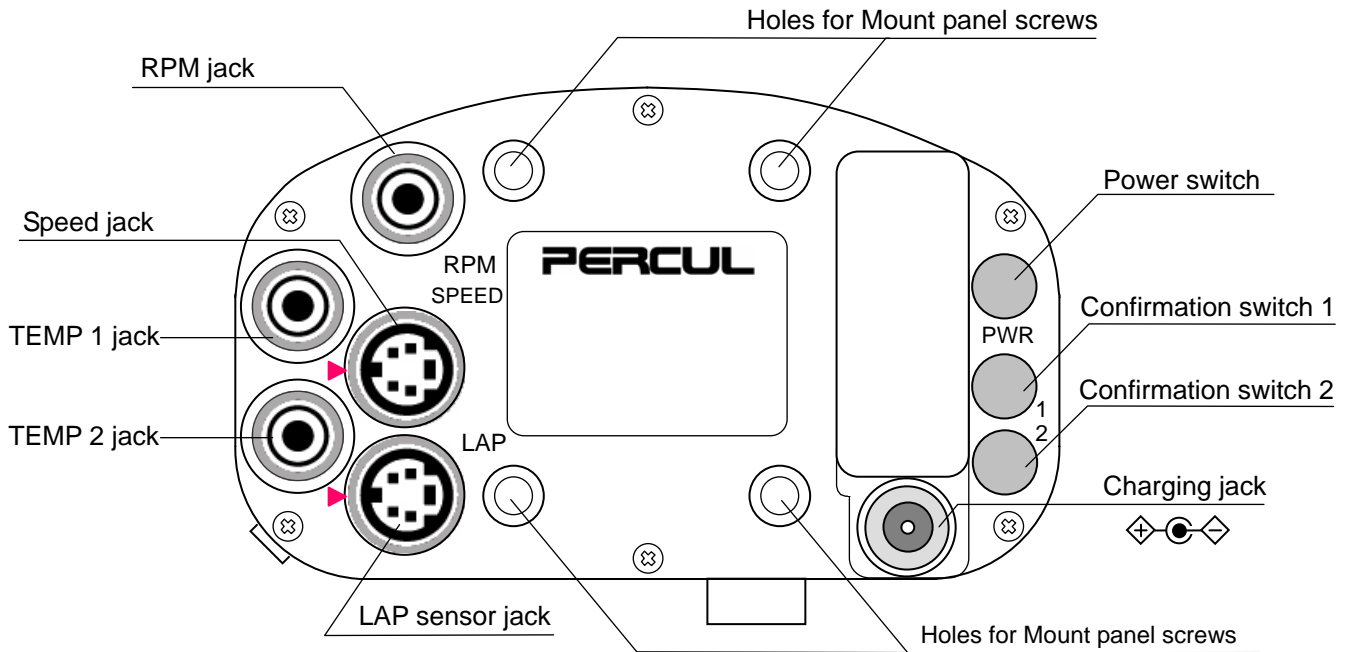

**Back**

### 3) **Charging the Control Unit**

1. Insert the DC plug of the AC adapter into the charging jack of the control unit.
2. Fit the adapter plug to the AC adapter. (if the adapter plug is attached)
3. After plugging the AC adapter into the power outlet, The quick charging cycle starts and the charging monitor lamp is illuminated. After quick charging cycle finishes, the monitor lamp goes out and trickle charge cycle starts. **Continue the trickle charge cycle for about 14-15 hours to fully charge the control unit battery.**

**Caution :** Charge the unit within a temperature range of 5 to 40°C.

#### **NOTE :**

A fully charged internal battery is capable of running Lite-10 All continuously for up to 13 hours. When the battery is running low, a "V" starts flashing on the display and the power lamp will go out in about an hour due to the auto power off function. If the power switch is turned ON again before charging, auto power off will not function and the total discharge of the battery will take place causing loss of all stored data in the control unit.

If the unit has not been used for some time, charge the battery fully before use. Sometimes quick charging may start after some trickle charging. If this occurs, it is not an error. If quick charging immediately followed by trickle charging occurs over and over even though the internal battery is not charged, activate the battery by turning the power switch ON to discharge it after a 15 hour trickle charge. Repeat this process 2 or 3 times.

#### **Important notice**

If you expect not to use the unit for a long time, charge the battery fully this to avoid total discharge. The unit gradually consumes the charge in battery even though the power switch is off.

**Use only a Percul approved charger, the use of other types of chargers can cause damage to the unit and void your warranty.**

#### 4) **Installation**

##### 1. **Control unit**

1. Attach the mount panel to the rear of the control unit with the supplied 4 small screws.
2. Install the control unit to the steering wheel by fastening the supplied long screw.



##### 2. **Magnetic sensor (for kart)**

1. Put the sensor on the floor panel with two-sided tape. Fix the sensor on the floor panel by a screw or tying bands\* through the hole of the sensor. Make sure that the head of the sensor is placed in the direction of travel. Please see the picture on the next page. \*A screw and tying bands are not supplied.
2. Keep the sensor 5cm or more away from any main chassis rails.
3. Insert the magnetic sensor connector into the LAP sensor jack of the control unit. When plugging the magnetic sensor into the control unit, make sure the power switch is off. If the power switch is on, lap count may automatically start. It is not an error. Press the CLEAR key to stop the count.

##### **<Sensitive Magnetic sensor>**

1. Put the magnetic sensor to the side box on the other side of the engine with two-sided tape. Fix the sensor to the side box by a screw or tying bands\* through the hole of the sensor. Make sure that the head of the sensor is directed to the ground. Please see the picture on the next page. \*A screw and tying bands are not supplied.
2. Insert the magnetic sensor connector into the LAP sensor jack of the control unit. When plugging the magnetic sensor into the control unit, make sure the power switch is off. If the power switch is on, lap count may automatically start. It is not an error. Press the CLEAR key to stop the count.

##### **Caution**

Keep the sensor away from the ignition coil and plug cord that generate magnetism as far as possible. Keep the sensor cable away from the pulse lead cable.

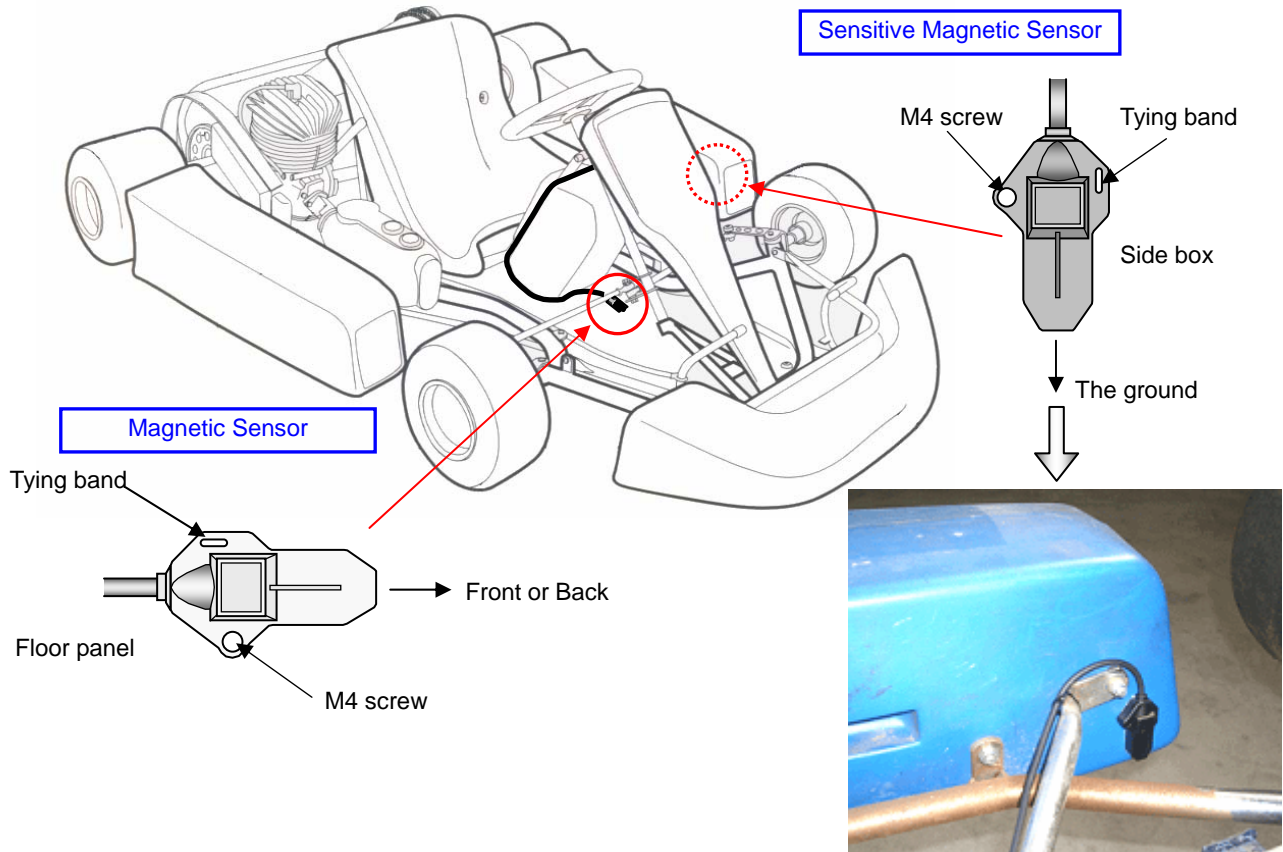

### 3. Pulse lead for RPM

1. For Kart engines, replace the spark plug cap with a noise-suppressing product (NGK LB05EMH or equivalent) or use a resistor spark plug.
2. Clip the lead to where RPM is correctly measured such as where all the plug leads are gathered or the ignition coil lead.
3. Insert the pulse lead connector into the REV jack of the control unit. Make sure the cable is affixed to the chassis in several positions.



#### **Caution**

The RPM pulse lead has not been soldered to the clip to help dampen large engine ignition pulses that may enter the microcomputer of the control unit from the RPM pulse lead. If there is any damage that needs repair, ensure there is no electrical contact between the cable and clip.

**4. Wheel speed sensor** \*A speed sensor is optional.

1. Arrange the supplied magnet triggers around the axle or wheel. Usually 4 to 10 magnets are used. The speed pulse length (outer circumference of tire / number of magnets) should be between 100mm and 999mm. Determine the number of magnets to set the speed pulse length in this range.
  2. Affix the magnets with tape. If you mount the magnets on the sprocket or wheel by drilling holes, make sure that might reduce their strength.
  3. Install the sensor bracket\* on the place for ease installation of the sensor. (For example, on the outside bearing hanger on the brake side of the chassis) Install the wheel speed sensor so that the sensing surface is close to the magnets but not touching them. Any touching would cause damage to the sensor. The distance between the sensing surface and the magnets depends on the installation condition, but a gap of 5mm or under is recommended.
  4. Insert the wheel speed sensor connector into the speed sensor jack of the control unit.
- \*Wheel speed sensor bracket and screws are not supplied.

**Caution**

During installation, do not subject the upper resinous part of the sensor to any stress by pinching or wrenching it with a tool.



**5. Liquid sensor** \*A liquid sensor is optional.

1. Cut the radiator hose and install the hose joint to connect the both edges of the cut hose.
2. Fasten the bands\* the both sides of the hose joint. \*These bands are not supplied.
3. Install the liquid sensor into the hose joint. Bend the spring/cable of the sensor roundly like in the picture below. Fix the both side of the green connectors on the radiator hose.
4. Fix the cable on the radiator side of the vehicle in several points.
5. Insert the liquid sensor connector into the TEMP sensor jack of the control unit.

Fix the both sides of the connectors.

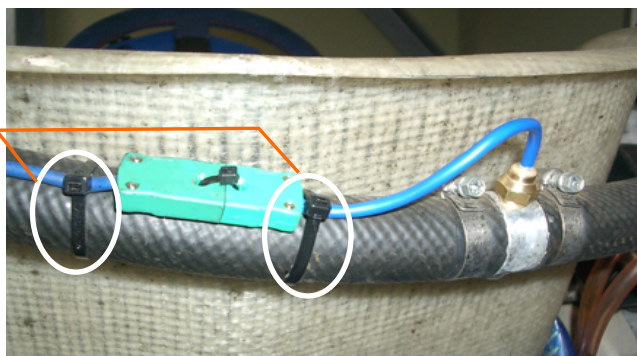

**Caution**

Keep the sensor away from the engine head. It may occur an error due to the engine noise.

## 6. Spark plug temperature sensor

1. Remove the spark plug and ring.
2. Confirm if the sensor ring fits in the spark plug. Fit the sensor ring in the spark plug.
3. Place back the spark plug on the cylinder head and tighten the spark plug.
4. Make a hole in a cooling fin and fix the sensor spring through the hole. See the picture below.
5. Insert the spark plug temp. sensor connector into the TEMP sensor jack of the control unit.

Fix the sensor spring  
on the cooling fin.

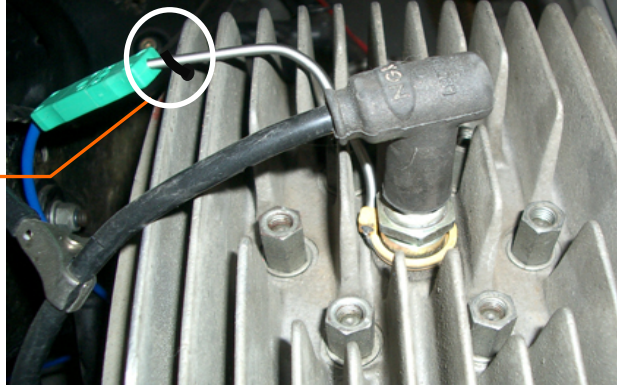

## 5) Setting of Parameters

### To enter the parameter setting mode;

1. Turn on the control unit.
2. The READY command must appear on the screen. If it is not displayed, press CLEAR key to display the READY command.
3. Press the Mode and SHIFT keys simultaneously for 3 seconds. The READY command should disappear and the parameter number should appear in the bottom right hand side of the screen.

### 1. Parameter No.1: Number of Segments

Set the number of segments from 1 to 4.

1. In the parameter setting mode, display the parameter number 1. If the number 1 is not displayed, press MODE key to scroll the numbers.
2. Press SET key to select the numerical value from 1 to 4. If there are 3 buried magnets on the course, select "3".
3. Press MODE key to advance to the next parameter setting or press CLEAR key to exit.

### 2. Parameter No.2: Sensor Off Timer

This function allows the user to set the control unit to ignore any other transmitter or magnetic pickups in the course for a set time period after the vehicle passes the start point pickup. This is used to an error occurring when transmitters with the same channel number are installed. This is also used to measure only lap times by canceling any other buried magnets in the course where multiple magnets are used.

1. In the parameter setting mode, display the parameter number 2. If the number 2 is not displayed, press MODE key to scroll the numbers.
2. Press SET key to set the time. To scroll the values backward, press SHIFT key.  
[0:01] The default setting is one second. Keep this default for regular driving.  
[0:00] **Do not set this value.** The off timer will be set 10 minutes.
3. Press MODE key to advance to the next parameter setting or press CLEAR key to exit.

**Note:** Do not set a time that exceeds the expected lap times.

### 3. [Parameter No.3: REV Position](#)

Enter the REV position according to the following table.

P:1	4 Stroke	1 Cylinder
P:2	2 Stroke 4 Stroke	1 Cylinder 2 Cylinders
P:4	2 Stroke 4 Stroke	2 Cylinders 4 Cylinders

1. In the parameter setting mode, display the parameter number 3. If the number 3 is not displayed, press MODE key to scroll the numbers.
2. Press SET key to select the desired REV position.
3. Press MODE key to advance to the next parameter setting or press CLEAR key to exit.

### 4. [Parameter No.4: Shift Lamp](#)

This function allows the user to set the value at which information lamps will start being illuminated as a shift lamp as the following drawing. This setting is mainly used to advise the driver of the timing for gear change.



1. In the parameter setting mode, display the parameter number 4. If the number 4 is not displayed, press MODE key to scroll the numbers.
2. Press SHIFT key to until the numerical value to be changed starts flashing.
3. Press SET key to select a value. Set the desired RPM, at which the shift lamp starts being illuminated, by repeating operation 2 and 3.
4. Press MODE key to advance to the next parameter setting or press CLEAR key to exit.

### 5. [Parameter No.5: Red Line](#)

This function allows the user to set the value at which information lamps will start being illuminated and flashing as a red line Rev limit as the following drawing.



1. In the parameter setting mode, display the parameter number 5. If the number 5 is not displayed, press MODE key to scroll the numbers.
2. Press SHIFT key to until the numerical value to be changed starts flashing.
3. Press SET key to select a value. Set the desired RPM, at which the shift lamp starts being illuminated and flashing, by repeating operation 2 and 3.
4. Press MODE key to advance to the next parameter setting or press CLEAR key to exit.

### 6. [Parameter No.6&7: Temperature Alarm](#)

This function allows the user to set the value at which information lamps will start flashing as an alarm for a temperature increase as the following drawing.

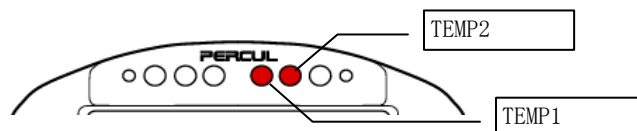

\* The measurement accuracy is dependable in the range of 5°C/41F to 300°C/572F. Liquid sensor and Spark plug temp sensor are available for Lite-10 All. If you choose m/h for the parameter No.9, the temperature values are automatically displayed in Fahrenheit.

1. In the parameter setting mode, display the parameter number 6/7. If the number 6/7 is not displayed, press MODE key to scroll the numbers.
2. Press SHIFT key to until the numerical value to be changed starts flashing.
3. Press SET key to select a value. Set the desired RPM, at which the shift lamp starts being illuminated and flashing, by repeating operation 2 and 3.
4. Press MODE key to advance to the next parameter setting or press CLEAR key to exit.

**8. [Parameter No.8: Speed Pulse Length](#)** \*A speed sensor is optional.

Enter the speed pulse length to measure the accurate speed data with the control unit. Measure the outer circumference of tire and divide this by the number of magnets. The speed pulse length (= outer circumference of tire / number of magnets) should be between 100mm and 999mm.

1. In the parameter setting mode, display the parameter number 8. If the number 8 is not displayed, press MODE key to scroll the numbers.
2. Press SHIFT key until the numerical value to be changed starts flashing.
3. Press SET key to select a value. Set the desired speed pulse length (mm) by repeating operation 2 and 3.
4. Press MODE key to advance to the next parameter setting or press CLEAR key to exit.

**9. [Parameter No.9: Unit of Speed \(km/h or m/h\)](#)** \*A speed sensor is optional.

1. In the parameter setting mode, display the parameter number 9. If the number 9 is not displayed, press MODE key to scroll the numbers.
2. Press SET key to select the unit of speed km/h or m/h.
3. Press MODE key to advance to the next parameter setting or press CLEAR key to exit.

\* If you choose m/h for this parameter, the temperature values are automatically displayed in Fahrenheit.

**10. [Parameter No.10: Baud Rate \[Default: 576\(57600bps\)\]](#)** \*A download cable is optional.

1. In the parameter setting mode, display the parameter number 10. If the number 10 is not displayed, press MODE key to scroll the numbers.
2. Press SET key to select the baud rate. \* Keep the default setting for regular use.
3. Press MODE key to advance to the next parameter setting or press CLEAR key to exit.

\* An optional serial communication cable is needed for data download.

**11. [Parameter No.11: Backlight \(ILLUM\)](#)** \*A backlight is optional.

This function will not available unless the optional backlight is equipped with the display.

1. In the parameter setting mode, display the parameter number 11. If the number 11 is not displayed, press MODE key to scroll the numbers.
2. Press SET key to select the numerical value : OFF(0), ON (1), ON (2), or ON (3). **The brightness of the backlight is only one level.**
3. Press MODE key to advance to the next parameter setting or press CLEAR key to exit.

**6) Selecting Data Item that can be displayed during Driving**

You can choose the data item that can be displayed during driving as follows;

- SEC Current segment time
- V Current voltage of the internal battery
- rpm Current RPM

1. Confirm that READY appears on the display. If it is not displayed, press CLEAR key to display it.
2. Press SET key to display SEC, V and rpm. The flashing comment is the current setting. Press SET key several times to make the desired comment flashing. Press CLEAR key or wait for a few seconds. Then the comment is displayed.

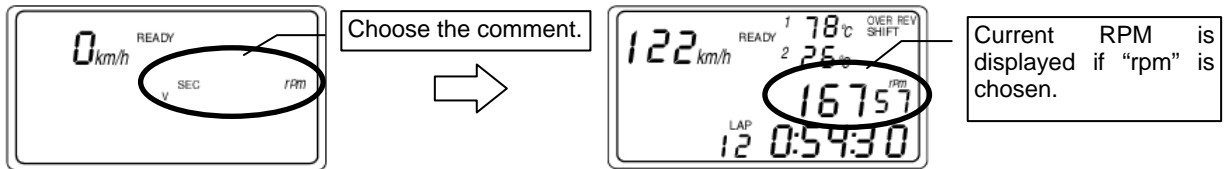

**7) Monitoring Data during Driving**

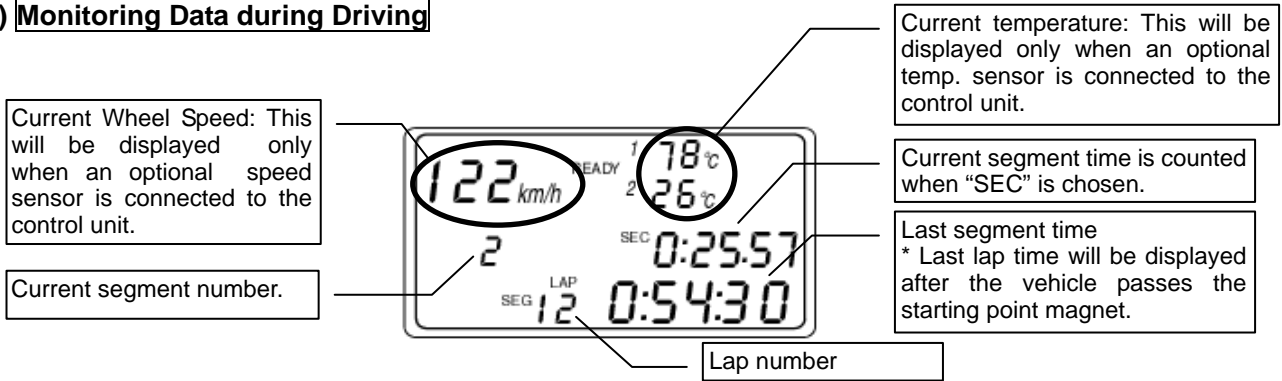

**8) Reviewing Data from the Display**

\*Temperature isn't displayed until a temperature is plugged into the control unit.

<Lap data & BEST LAP data>

1. Confirm that READY appears on the display. If it is not displayed, press CLEAR key to display it.
2. To review individual lap data, press SHIFT or MODE key. LAP comment starts flashing and the latest lap data will be displayed. Press SHIFT key to scroll the lap data from the oldest lap to the latest one. To scroll the lap data backward, press MODE key.

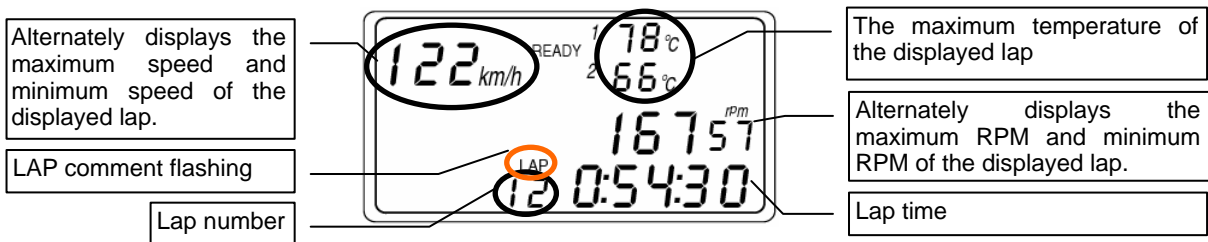

3. To display BEST LAP, press MODE key for 3 seconds. The best lap is displayed with the BEST LAP comment.

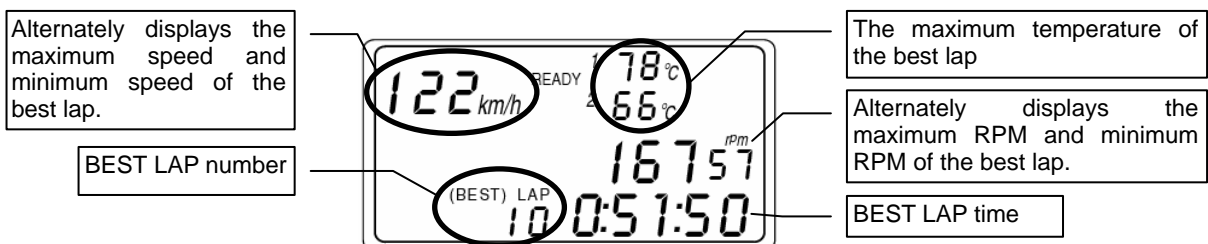

### <Segment data for a lap>

4. To review segment data, display the desired lap data. Press Confirmation switch 1 in the back of the control unit. SEG comment starts flashing and the segment data of the lap will be displayed. Press Confirmation switch 1 to scroll the segment data. Press Confirmation switch 2 to return to the lap data.

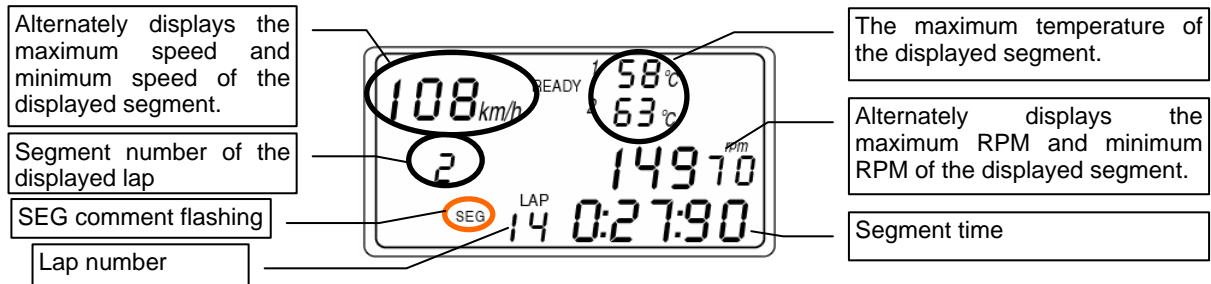

### <The same segment data for individual lap & BEST SEG data>

5. Press Confirmation switch 1 several times to display the desired segment data. Press MODE key or SHIFT key to scroll the lap number. The same segment data for each lap will be displayed.
6. To display BEST SEG, press MODE key for 3 seconds. The best segment data of the displayed segment will be displayed.

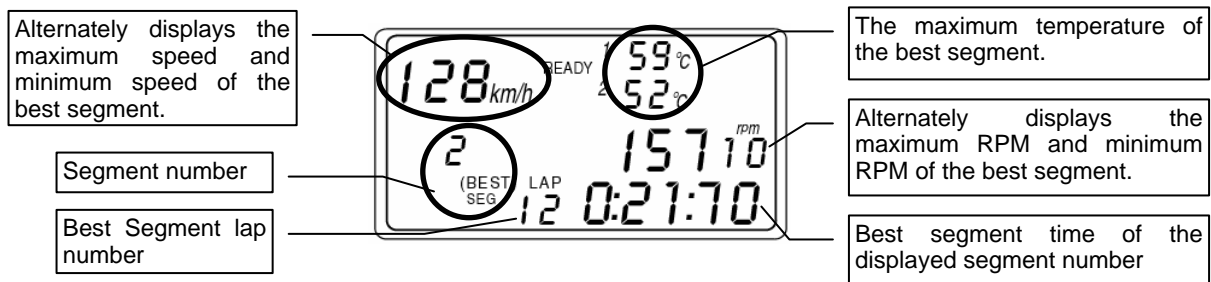

7. Press CLEAR key to finish reviewing data.

### 9) **How to Delete Individual Lap Data**

1. Confirm that READY appears on the display. If it is not displayed, press CLEAR key to display it.
2. Press MODE or SHIFT key to display the lap data to be deleted.
3. Press SET and CLEAR key simultaneously for 3 seconds.
4. Press CLEAR key to finish deleting data.

### 10) **How to Delete all the Lap Data in a Single Block**

1. Confirm that READY appears on the display. If it is not displayed, press CLEAR key to display it.
2. Press SET and CLEAR key simultaneously for 3 seconds.

### 11) **How to Display and Reset Engine Running Time and Odometer**

1. Confirm that READY appears on the display. If it is not displayed, press CLEAR key to display it.
2. Press MODE and CLEAR key simultaneously.
3. Press CLEAR key to finish displaying the meters.

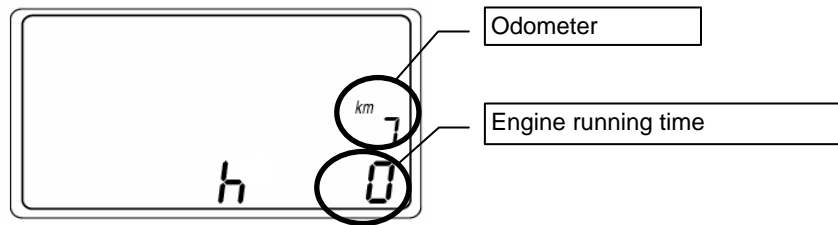

4. To reset the odometer, press SET and CLEAR key simultaneously for 3 seconds.
5. To reset the engine running time, press MODE and CLEAR key simultaneously for 3 seconds.

**12) Data Download**

\*An optional serial communication cable is required for data download.  
 \*Lapcom Terminal and Lapcom Analysis are not available with this device.

**<How to install Lapcom Loader>**

1. Double click Setup.exe file from Lapcom Loader folder.



2. Installation will start.

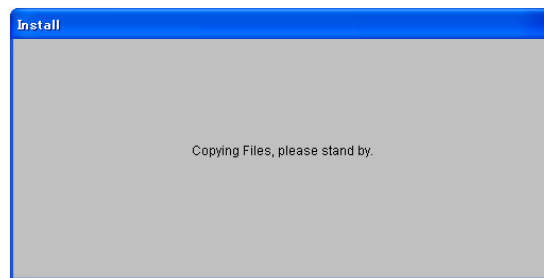

3. Click OK button.

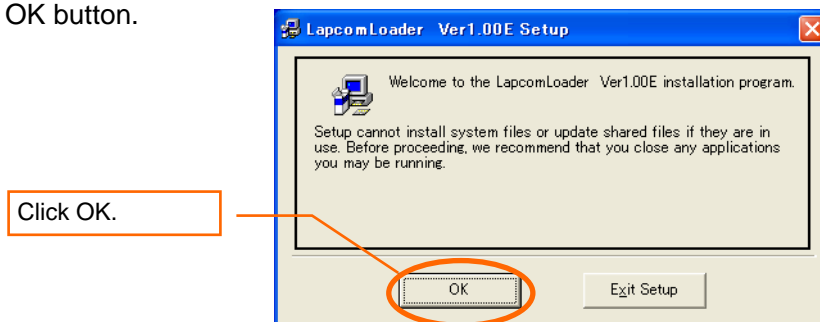

4. Click the button.

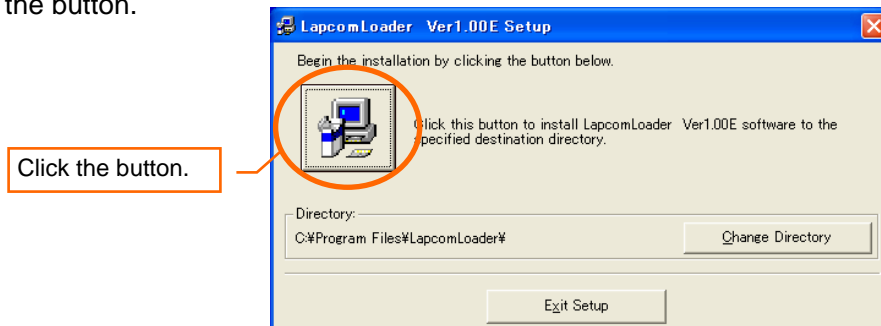

5. Click the button.

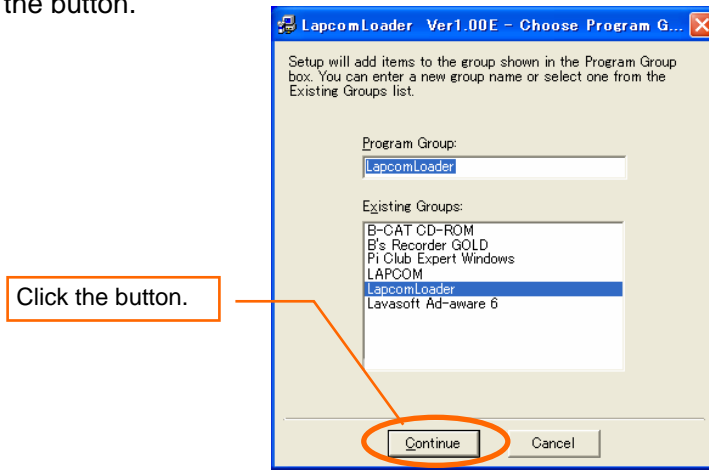

6. Setup starts.

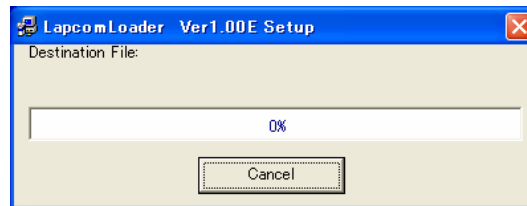

7. Click OK button to complete the installation.



### <How to download >

1. Connect the serial communication cable to the COM port of the control unit and PC. Turn on the power of the control unit.
2. Open Lapcom Loader. Press PORT button. PORT SET window is opened. Choose the com port and baud rate. \* The baud rate should be the same as the control unit. Click OK button.

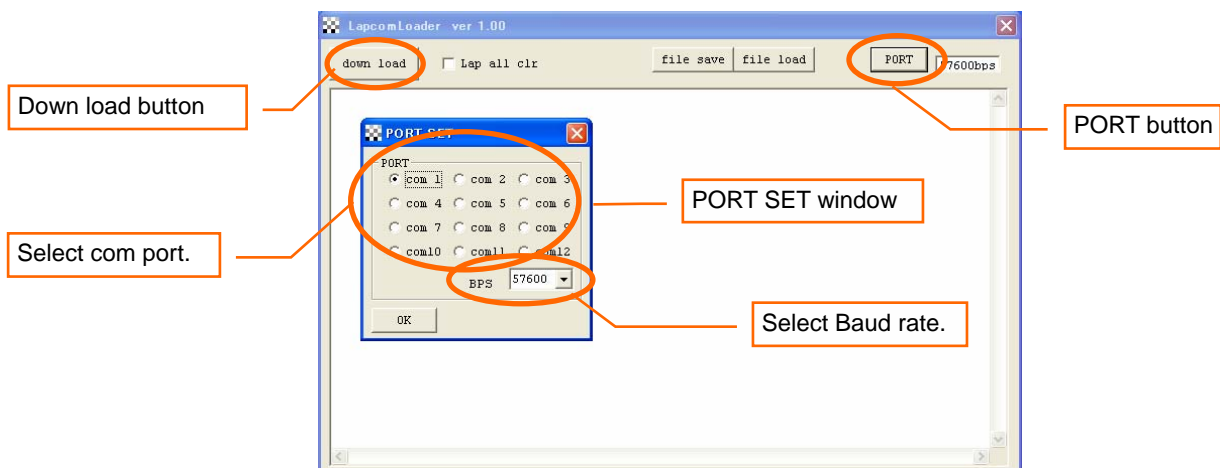

- Press Down load button. Then the stored data will be transmitted from the control unit to PC. If you check the Lap all clr box before pressing Down load button, All the data will be deleted in the control unit after the download.

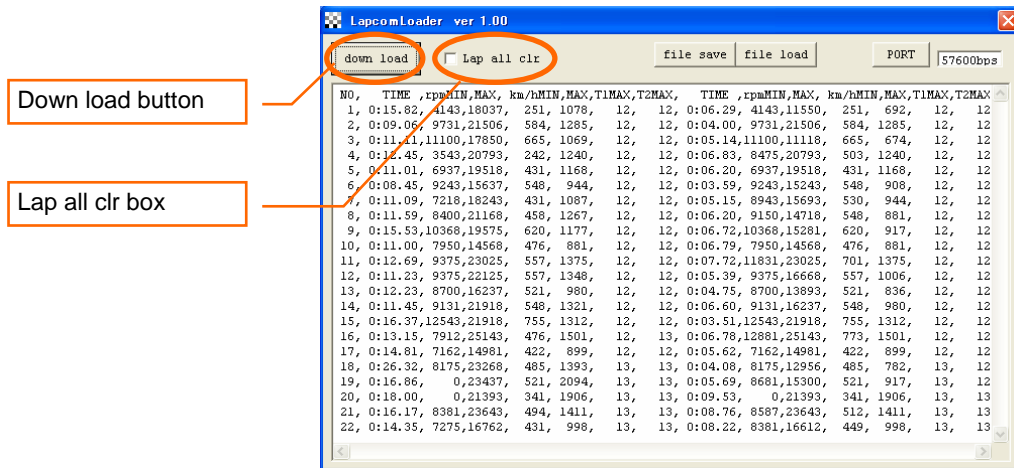

- Press file save button to open SAVE window. Put a file name and press OK button. A text data will be saved in the default folder; C:¥Program Files¥LapcomLoader.

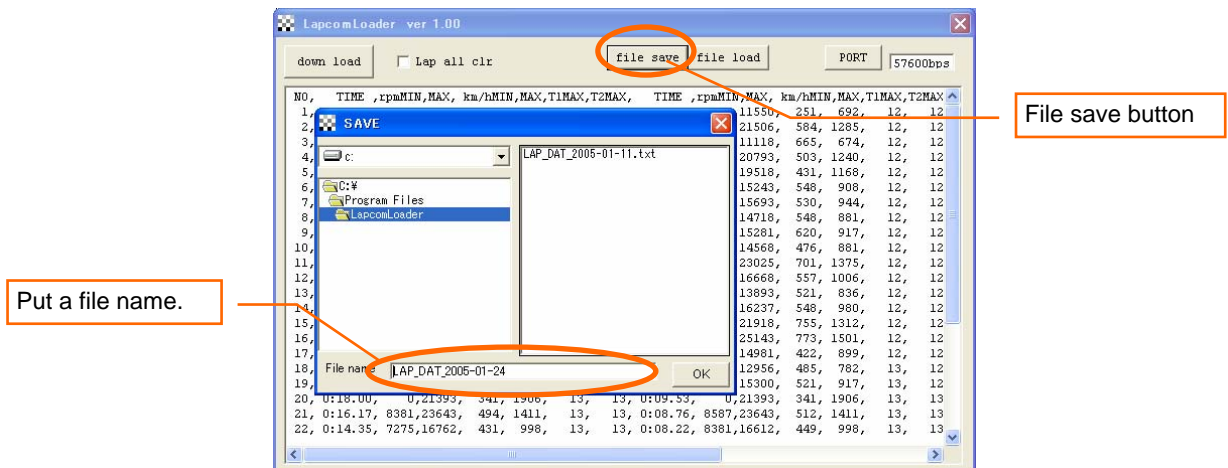

- To load the saved file, press File load button. LOAD window will be opened. Choose the desired file and press OK button. The data will be displayed.

